

### Electrical Specifications

Catalogue Number	5102RVF	E5102TRVF
C-Bus Input Voltage		
Normal Operation	15 - 36Vd.c. @ 0mA Nominal	
Programming mode	15 - 36Vd.c. @ 36mA Nominal	
Mains Supply	192 - 264Va.c.	90 - 130Va.c.
Mains Frequency	48 to 62 Hz	
Mains Power Consumption	<3W Maximum OFF state consumption	
Rated Relay Load Current	10A per channel	
Relay Electrical Endurance	(operations at rated load current)	
Resistive Load	60,000 minimum	
Incandescent Load	60,000 minimum	
Fluorescent Load	60,000 minimum	
Inductive Load	60,000 minimum	
Electrical Isolation Rating (Mains to C-Bus)	3.5kVRMS for one minute (opto-isolated UL recognised File No. E54915)	

### Ambient Conditions

Operating Temperature	0 - 50°C
-----------------------	----------

### Terminals

C-Bus Side	Screw Terminals accommodate 6 x 0.2mm <sup>2</sup>
Output Side	Spring Terminals accommodate 0.2 - 1.5 mm <sup>2</sup> (24 - 16 AWG) solid or stranded cable

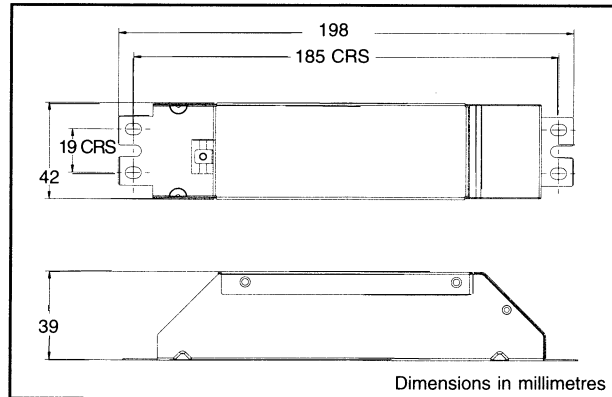

### Product of Gerard Industries Pty Ltd

ACN 007873 529  
 12 Park Terrace, Bowden, South Australia 5007  
 Telephone (08) 8269 0511 Facsimile (08) 8340 1724  
 Internet <http://www.clipsal.com.au>  
 E-Mail [Plugin@clipsal.com.au](mailto:Plugin@clipsal.com.au)

Gerard Industries Pty Ltd reserves the right to change specifications or designs described in this manual without notice and without obligation.

C-Bus™

## C-Bus Two Channel Voltage Free Relay

### Installation Instructions

**5102RVF**  
**E5102TRVF**

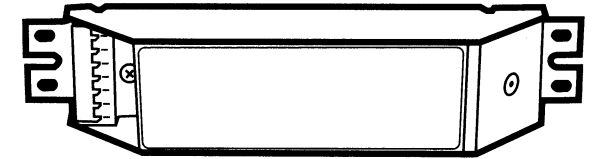

### Product Range

5102RVF - C-Bus Two Channel Voltage Free Relay (240V)  
 E5102TRVF - C-Bus Two Channel Voltage Free Relay (110V)

### Description

The 5102RVF/E5102TRVF Two Channel Voltage Free Relay is a C-Bus output device designed to provide two pairs of normally open relay contacts for general switching applications.

### Capabilities

The Two Channel Voltage Free Relay Unit is comprised of two relay switches, controlled by instructions from the C-Bus Network. Manual Override facilities are available, permitting stand alone operation in the case of a power loss on the C-Bus Network. A special Programming mode can be used to configure the unit prior to connection of the mains supply. The unit isolates the mains power from the safe extra low voltage C-Bus Network.

*The Two Channel Voltage Free Relay Unit differs from most other C-Bus devices in that it does not draw any current from the C-Bus Network during normal operation.*



## Wiring Instructions

### 5102RVF / E5102TRVF C-Bus Two Channel Voltage Free Relay Units

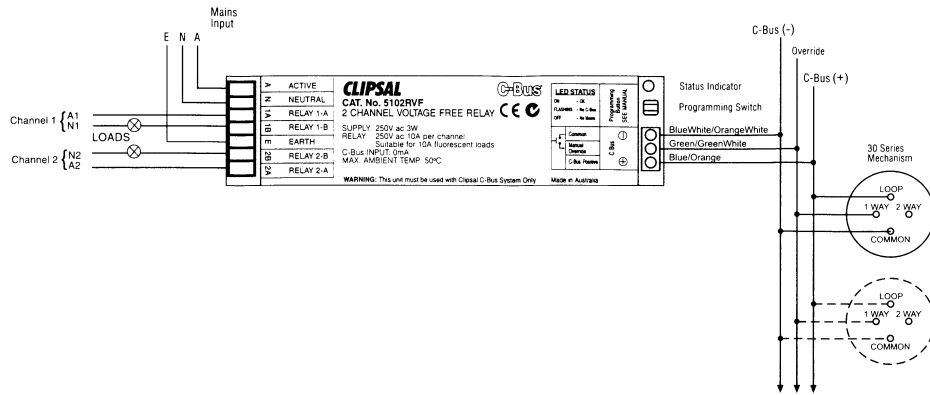

### Status Indicator

An indicator has been provided to show the status of the C-Bus connection. This indicator is located under the extra low voltage cover of the unit.

Indicator	Mains Power	C-Bus Communications
ON	OK	OK
FLASHING	OK	ABSENT
OFF	ABSENT	UNKNOWN

### Manual Override Input

The centre terminal of the extra low voltage C-Bus connector provides a Manual Override facility. By shorting the Manual Override input with the C-Bus negative(-) terminal, both pairs of relay contacts will be forced to the ON state. Any C-Bus command will be ignored until the Manual Override Input short is removed. Upon release of the Manual Override Input, both pairs of relay contacts will be forced to the OFF state. At this time the C-Bus error detection/correction algorithms will dictate the state of the outputs.

### Stand Alone Operation

The C-Bus Two Channel Voltage Free Relay Unit can be operated as a 'stand-alone' device (no C-Bus connection) by means of the Manual Override Input. In this case cable type of between 0.2 and 1.5mm<sup>2</sup> (24-16AWG) of solid or stranded construction should be used, not exceeding one hundred metres in length for each terminal, C-Bus negative(-) or Override.

## Programming Switch

The Two Channel Voltage Free Relay can be programmed without a mains connection. The unit can be connected to any operational C-Bus Network capable of supporting two or more extra C-Bus units (current consumption in Programming mode approximately 36mA). The Programming Button may be pressed and held to enable the Programming mode. In this mode the unit may be configured using the C-Bus Installation Software, however the switched mains loads will not be functional until programming is completed, and a mains connection established. The Programming Switch should not be used during normal mains operation of the unit.

### Power Up Load Status

All C-Bus units have onboard non-volatile memory which is used to store the operating state of the unit in case of a power loss. The Two Channel Voltage Free Relay Units will, by default, retain the current output status if C-Bus power is lost. Please refer to the C-Bus Installation Software User's Guide for information relating to the programming of Relay Output Units.

### Connection to the C-Bus Network

It is recommended that Category 5 data cable be used, Clipsal catalogue number 5005C305B. Installation of the Two Channel Voltage Free Relay Unit on the C-Bus Network requires connection to the unshielded twisted pair C-Bus Network Cable. This connection is polarity sensitive, and is clearly marked on the terminal block of the Unit. The illustration below shows the recommended technique for cable termination giving the best electrical performance. Bootlace crimps may also be used to provide a highly reliable connection.

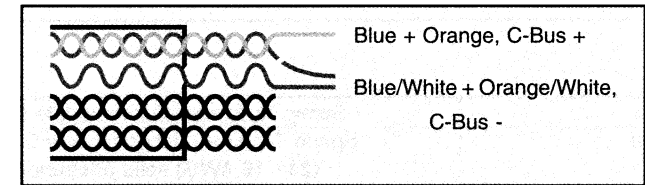

### Programming Requirements

As with other C-Bus units, the Relay Units must be programmed to set their unique identification and the mode of operation on the C-Bus Network. The C-Bus Installation Software can be used to configure all operational parameters including the specification of control sources, and power up options. Please refer to the C-Bus Installation Software User's Guide for information relating to the programming of Relay Output Units.

### Power Surges

The mains voltage must be limited to the range specified for any unit which is mains powered. Each unit incorporates transient protection circuitry and additional external power surge protection devices should be used to enhance system immunity to power surges. It is strongly recommended that overvoltage equipment such as the Clipsal 970 is installed at the switchboard.

### Megger Testing

Megger testing of an electrical installation that has C-Bus units connected will not cause any damage to C-Bus units. Since C-Bus units contain electronic components, the installer should interpret megger readings with due regard to the nature of the circuit connection.

### Important Warning

The use of any non C-Bus Software in conjunction with the hardware installation without the written consent of Gerard Industries Pty Ltd may void any warranties applicable to the hardware.